

# Earthquake<sup>®</sup>

## ***CRT ROTOTILLERS OPERATORS MANUAL***

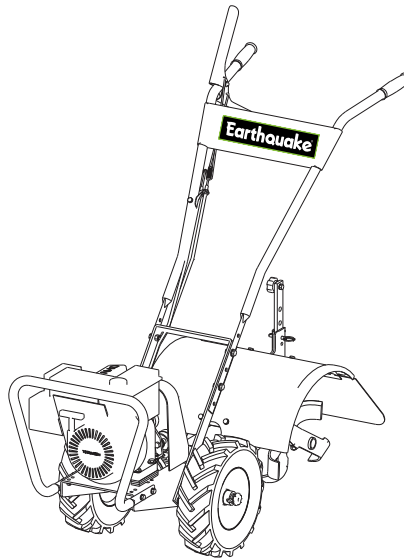

**5055C  
BRIGGS & STRATTON  
4-CYCLE 206CC  
8.50 FT-LBS GROSS TORQUE**

**6065VEC  
VIPER ELECTRIC  
4-CYCLE, 196 CC**

### CRT HANDLEBAR PARTS

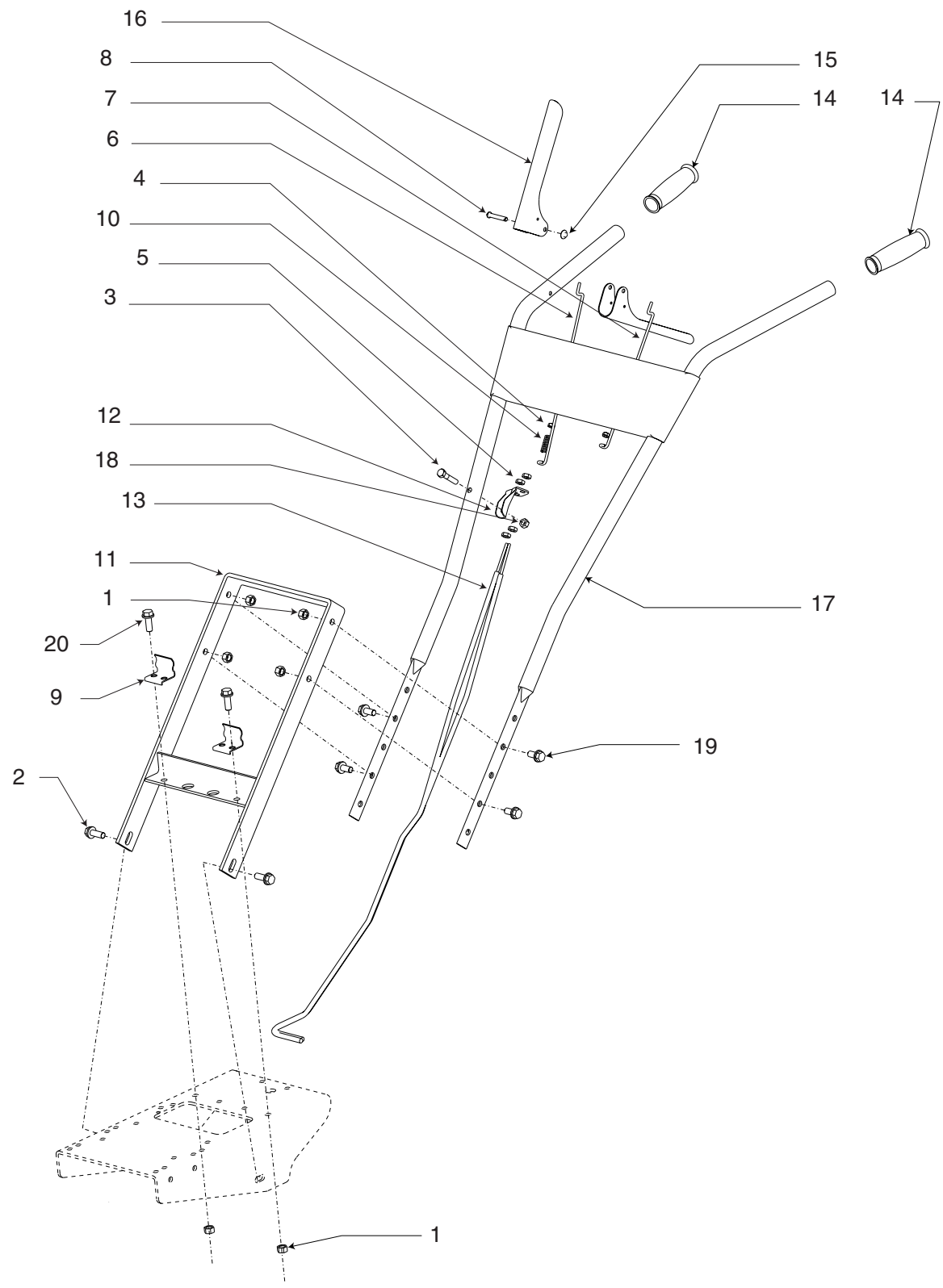

### CRT HANDLEBAR PARTS LIST

REF. NO.	PART #	DESCRIPTION	QTY.
1	2104	Nut Hex Two-Way 3/8-16	6
2	48762	Bolt 3/8-16 x 1" Carriage	2
3	503	Bolt 5/16-24x1" HH GR5	1
4	53606	Nut-Nyloc, #10	2
5	53607	Nut-Jam, 5/16-24	4
6	53612	Link 11-5/8" long	1
7	53613	Link 9-1/2" long	1
8	53614	Pin Clevis 1/4 x 1-1/2"	1
9	53618	Belt Guard Clip	2
10	53620	Spring Compression Forward Arm	1
11	53624	Handlebar Mount Weldment	1
12	53629	Cable Mount Bracket	1
13	53630	Cable - Rear Tine 39" Sheath	2
14	53631	Grip Handlebar 1" ID Flangeless	2
15	53632	Nut Push 1/4"	1
16	53650	Lever Control Rear Tine	2
17	53679	Handlebar Weldment	1
18	60G56	Nut-Bi-Way Lock, 5/16-18	1
19	90138	Bolt 3/8-16 x 3/4 Serrated Flange	4
20	90139	Bolt 3/8-16 x 1"	2

### 6065VE ELECTRICAL PARTS LIST

REF. NO.	PART #	DESCRIPTION	QTY.
21	300500	Grommet, 1/2" ID	1
22	300501	Nut, Wing M5 x .8	2
23	300502	Screw, Thumb M5 x .8	2
24	300503	Wiring Harness (not shown)	1
25	46122	Battery, 12-Volt 7-Amp	1
26	4656	Battery Box	1
27	4657	Cover, Battery Box	1
28	4660	Solenoid	1
29	4661	Charger Pigtail	1
30	4663	Cap, Charger Pigtail	1
31	4681	Battery Charger (not shown)	1
32	53106	Nut, Bi-Way Lock 1/4-20	2
33	53696	Support, Battery Box	1
34	64703*	Switch, Key	1
35	69169	Bolt, Phillips Truss Hd 1/4-20 x 3/4"	2
36	53705	Electrical Pack Assembly w/Charger (not shown)	1

\* On Model 6065VE the key switch is located on the engine.

### 6065VE BATTERY BOX EXPLOSION

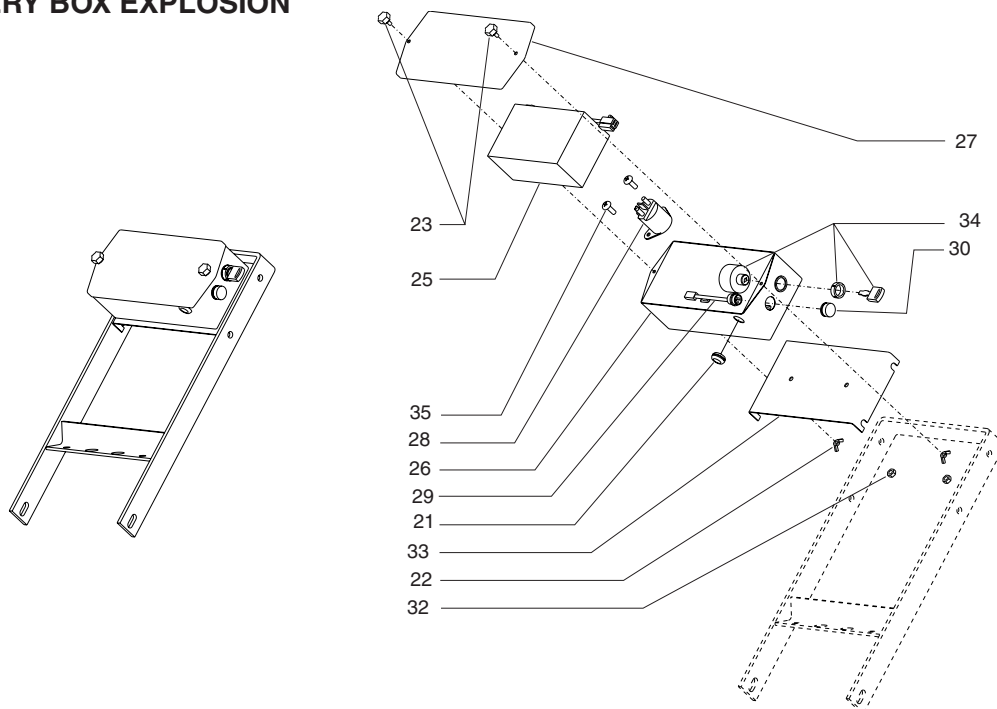

### CRT MOTOR MOUNT PARTS

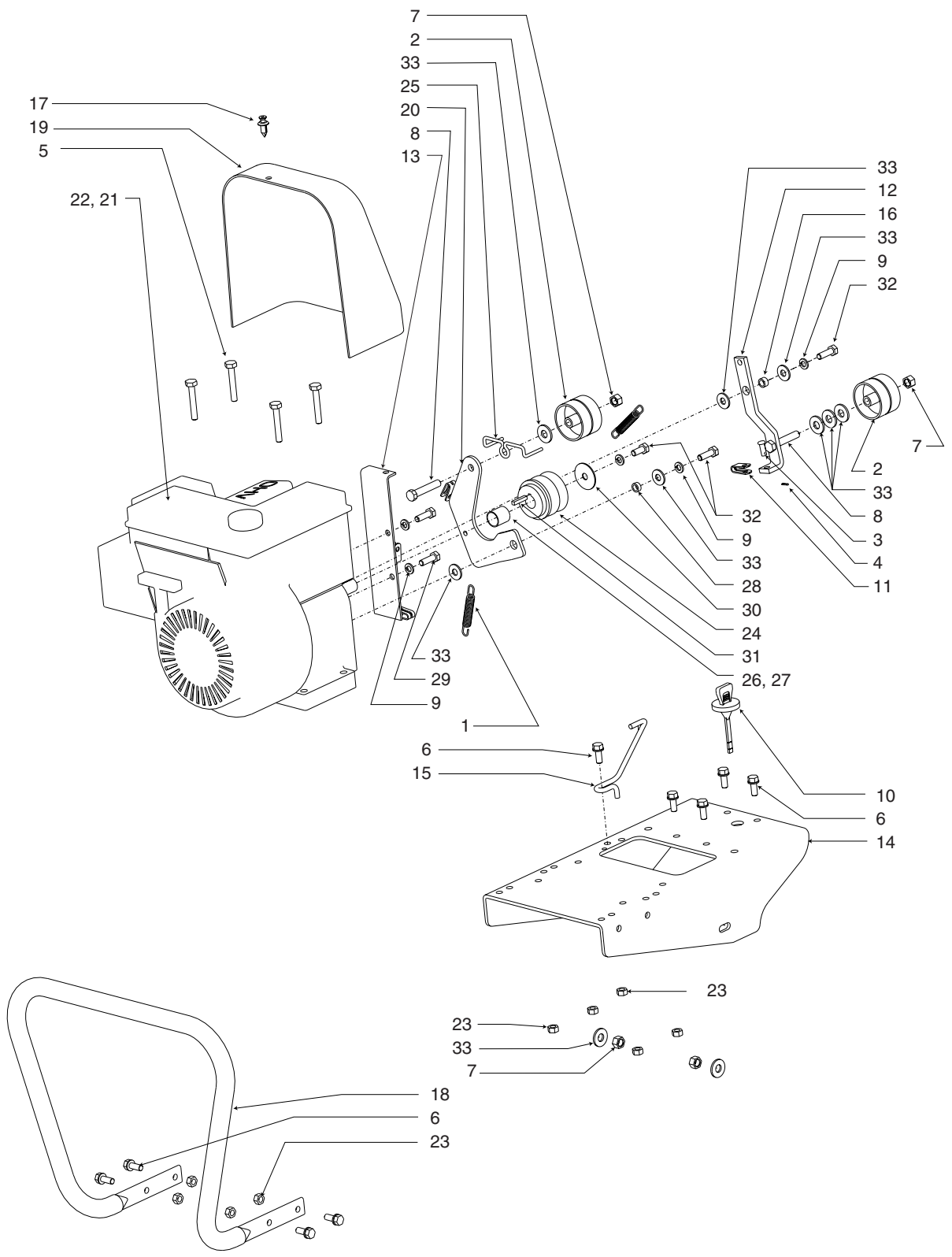

**CRT MOTOR MOUNT PARTS LIST**

REF. NO.	PART #	DESCRIPTION	QTY.
1	1407	Forward Arm Spring	2
2	1408	Forward Pulley Idler	2
3	1416	Clevis Pin	1
4	1418	Cotter Pin 5/64" x 1/2"	1
5	1423	Bolt 5/16-18 x 2"	4
6	1501	Bolt 5/16-18 x 3/4"	9
7	2104	Nut 3/8-16	4
8	48144B	Bolt 3/8-16 x 2"	2
9	504	Lock Washer Spring 5/16"	5
10	53413	Dip Stick	1
11	53596B	Clevis Yoke Zinc Plated	1
12	53617	Forward Arm	1
13	53622	Cable Pull Weldment	1
14	53623	Motor Mount	1
15	53633	Belt Guide	1
16	53637	Forward Arm Bushing	1
17	53638	Plastic Push-in Rivet	1

REF. NO.	PART #	DESCRIPTION	QTY.
18	53648	Bumper Guard (6065VE)	1
19	53649	Belt Guard	1
20	53682	Reverse Tine Weldment	1
21	31320E	Engine, Viper Electric 196 CC (6065VE)	1
22	60501	Engine, Briggs & Stratton 206 CC, 8.50 ft-lbs Gross Torque	1
23	60G56	Nut Bi-Way Lock 5/16-18	9
24	731	Two Groove Pulley 3/4"	1
25	739	Reverse Belt Guide	1
26	741	Spacer, Drive Pulley .900" (6065VE)	1
27	742	Spacer, Drive Pulley .550"	1
28	743	Reverse Arm Bushing	1
29	802	Bolt 5/16-24 x 3/4"	2
30	803	Washer 5/16" x 1-1/2"	1
31	804	Key 3/16" x 1"	1
32	810	Bolt 5/16-24 x 1"	3
33	WF516	Flat Washer 5/16"	10

### CRT TINES & HOOD PARTS

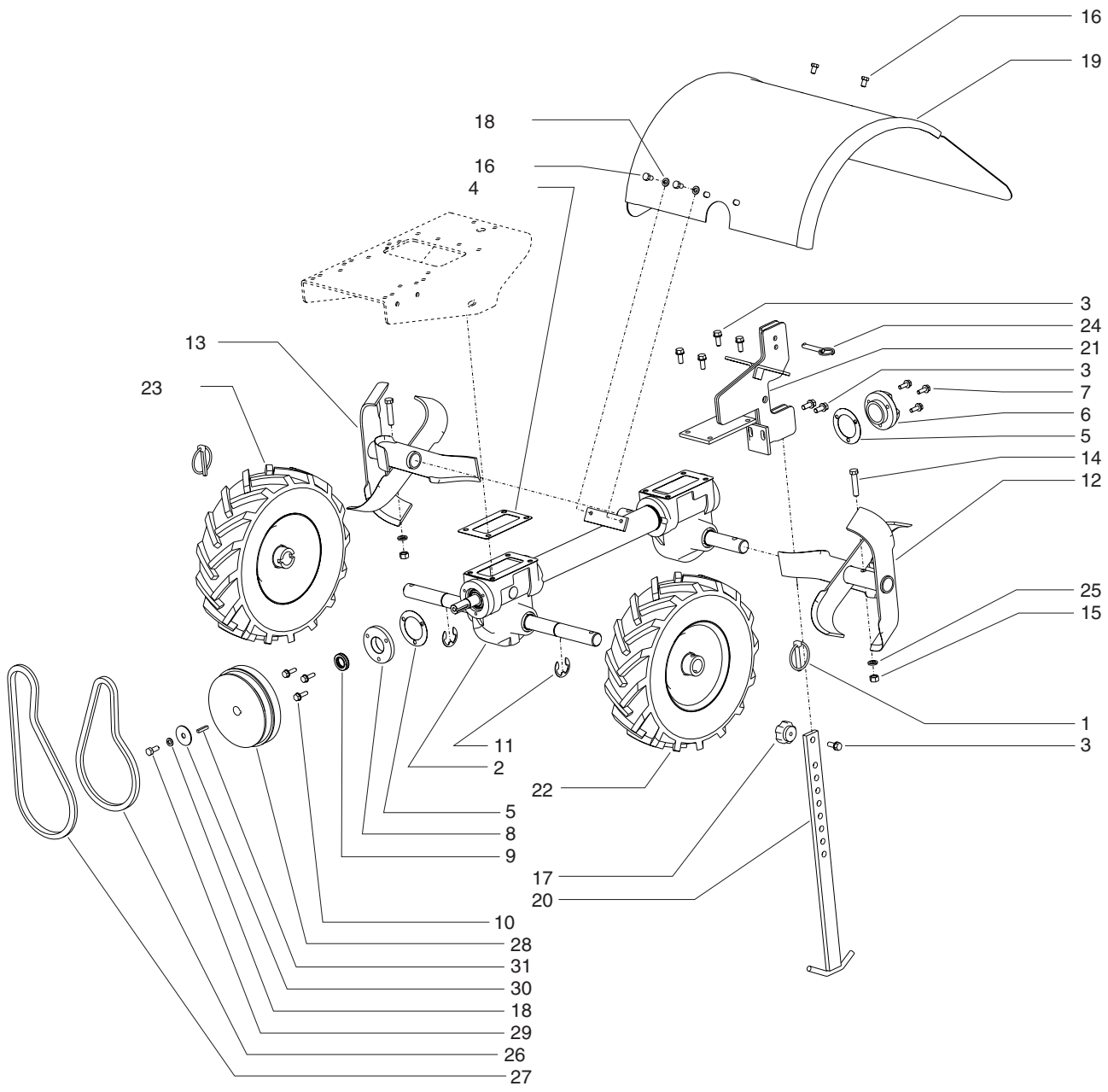

**CRT TINES & HOOD PARTS LIST**

REF. NO.	PART #	DESCRIPTION	QTY.
1	1103	Lock Pin 5/16" x 1-3/4"	2
2	1500CRT5	Transmission Assembly, Lock Pin	1
3	1501	Bolt 5/16-18 x 3/4"	7
4	1504	Gasket, Transmission	2
5	1500P103	Gasket, Bearing Cap	2
6	1500P102	Rear Bearing Cap	1
7	1500P101	Bolt 1/4-20 x 7/8"	3
8	1500P119	Front End Cap	1
9	1500P120	Seal Oil Drive Shaft	1
10	1500P101	Bolt 1/4-20 x 3/4"	3
11	1710	External Snap Ring	2
12	1900LCRT	Left Tine Set	1
13	1900RCRT	Right Tine Set	1
14	2001	Bolt 3/8-16 x 1-3/4"	2
15	2104	Nut, Bi-Way Lock 3/8-16	2
16	417	Bolt 5/16-18 x 1/2" HH GR5	4
17	48406	Black Knob 5/16-18	1
18	504	Lock Washer Spring 5/16"	3
19	415A	Hood Assembly	1
20	53655	Drag Weldment	1
21	53660	Tail Mount Depth Regulator	1
22	53698	Wheel, Left Lock Pin	1
23	53699	Wheel, Right Lock Pin	1
24	69170	Detent Pin 5/16 x 2" Zinc	1
25	719	Spring Washer 3/8"	2
26	727A	Forward Belt	1
27	730	Reverse Belt	1
28	740	Pulley, Two Groove Transmission	1
29	802	Bolt 5/16" x 1-1/2"	1
30	803	Washer 5/16" x 1-1/2"	1
31	804	Key 3/16" x 1"	1

## CRT WHEEL & TILLER SHAFT PARTS & PARTS LIST

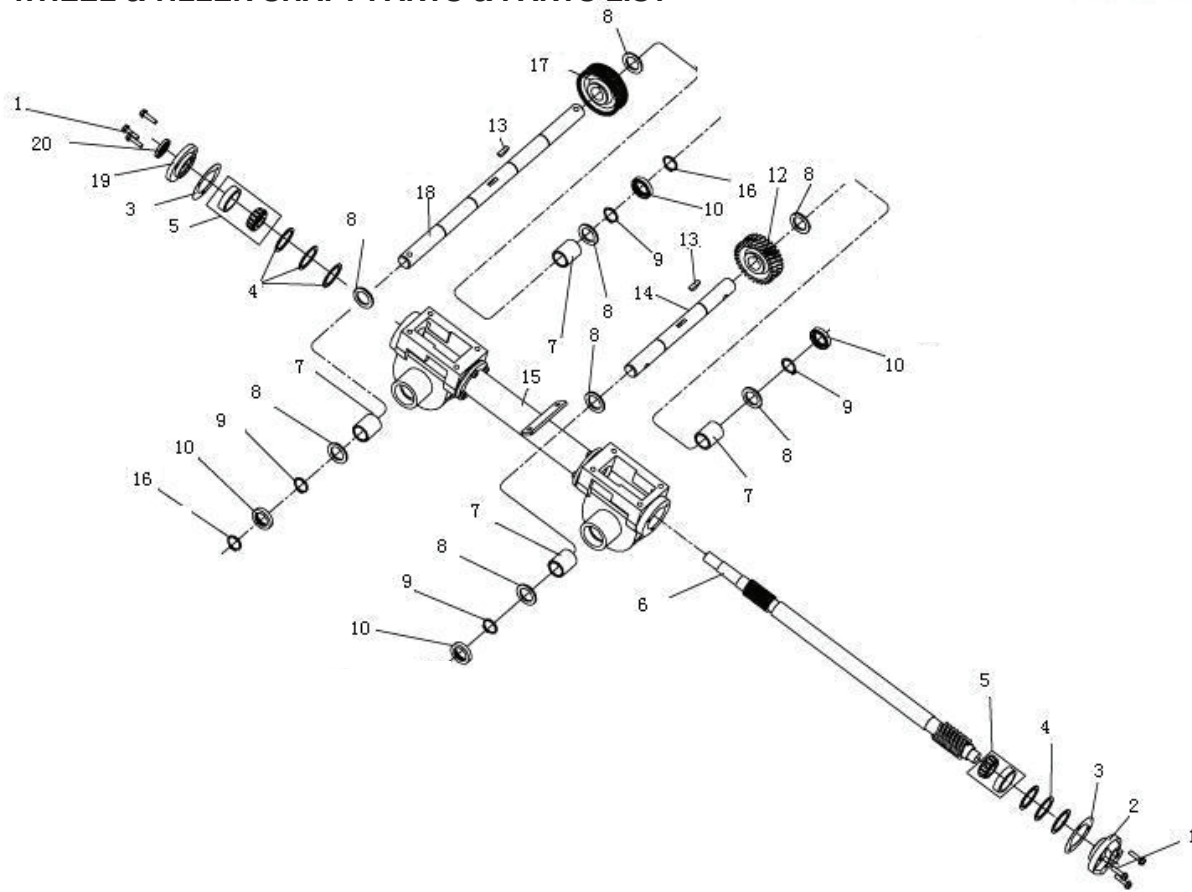

REF. NO.	PART #	DESCRIPTION	QTY.
1	1500P101	BOLT, M6 X 25MM	6
2	1500P102	COVER, REAR TRANSMISSION	1
3	1500P103	GASKET, FRONT AND REAR TRANSMISSION COVER	2
4	1500P104	SHIM, DRIVE SHAFT	6
5	1500P105	BEARING, TAPPED ROLLER	2
6	1500P506	SHAFT, DRIVE CRT SHAFT	1
7	1500P107	BUSHING, TINE AND WHEEL SHAFT	4
8	1500P108	SHIM, TINE AND WHEEL SHAFT	8
9	1500P109	RING, RETAINER INTERNAL	4
10	1500P110	SEAL, GREASE TINE AND WHEEL SHAFT	4

REF. NO.	PART #	DESCRIPTION	QTY.
12	1500P512	GEAR, WORM TINE CRT SHAFT	1
13	1500P113	KEY, WOODRUFF	2
14	1500P114	SHAFT, TINE	1
15	1500P115	HOUSING, TRANSMISSION	1
16	1500P116	RING, RETAINER EXTERNAL	2
17	1500P517	GEAR, WORM WHEEL CRT SHAFT	1
18	1500P118	SHAFT, WHEEL	1
19	1500P119	COVER, FRONT TRANSMISSION	1
20	1500P120	SEAL, GREASE INPUT	1